



TRPS/TRPA

Tiger Wire Rope Pulling Machine

INSTRUCTION GUIDE

- PLEASE PASS ONTO OPERATOR

Sticker here



Unit 1, Greensfield Industrial Estate,
Willowburn Avenue,
ALNWICK,
NE66 2DG
UK
+44 1665 605130

Woo Sing Industrial Co., Ltd
No 20 Yunong Road
Shih-lin
Taipei
Taiwan
+886-2-2831 3035

www.tigerlifting.com
Email: info@tigerlifting.com

Manual Tiger TRPS TRPA En 201510 v1.1





Operator Instruction Guide.



MUST READ BEFORE USE

1. It is important that this manual is read and fully understood and that all instructions are followed before using the wire rope puller.
2. The wire rope puller should be used by a trained and or experienced person who understands its use and will operate the unit in a responsible and safe manner.
3. Inspect the machine, rope and accessories for any damage or wear before use. Do not use the machine if it is not in good working order.
4. The supplier takes no responsibility for any consequential loss or damage if the unit has been dismantled or altered by an unauthorised person, especially if original parts were not used to repair the machine.
5. Do not use the machine to elevate people in any way.
6. The machine is for manual operation only. Do not attempt to use a motorized mechanical device to operate the machine. Only use the bar provided and do not extend the supplied handle.
7. Do not attempt to overload the machine as this could cause damage to person or machine.
8. Do not use the pulling machine in explosive environments.
9. Always ensure the puller is used or repaired by a competently trained person.

Contents:

- | | |
|---|---|
| 1. Description of Tiger Wire Rope Pulling Machine | 9. Replacing the shear pins |
| 2. Rigging arrangements | 10. Wire rope |
| 3. Installing the wire rope | 11. Maintenance instructions |
| 4. Releasing and closing the jaws | 12. Warnings against hazardous operations |
| 5. Anchoring | 13. Troubleshooting |
| 6. Operation | 14. Health and Safety at work |
| 7. Releasing the wire rope and storage | 15. Exploded Diagrams |
| 8. Safety devices | |

For details of the full Tiger product range visit our website: www.tigerlifting.com

Due to our policy of continual product development, dimensions, weights and specifications may change without prior notice.

© Copyright Tiger Lifting UK Limited. No part of this manual shall be reproduced, transmitted, transcribed, translated into any language human or electronic, stored in any electronic retrieval system, in any form without the written permission of Tiger Lifting UK Limited, Alnwick, UK





1. Description of Tiger Wire Rope Pulling Machine

The manual wire rope puller is a hand operated lifting and pulling device. The puller could also be used for lowering, tensioning and guying which makes it a versatile, portable and multipurpose tool.

The principle function of the wire puller is that the rope passes through mechanical jaws rather than being reeled on a drum of a puller or conventional winch. The tension of the rope is applied by means of two pairs of self-energized jaws which apply a grip onto the wire rope in sections. The effort is transferred to the jaws by two parallel levers, one for forward operation and the other for reverse operation. A telescopic bar, fitted to either the forward or reverse lever, transmits the effort to the jaw mechanism. This parallel clamping system provides an evenly distributed grip at a lower force, resulting in less rope wear. The load is held securely at all times.

Three shear pins will be supplied with all models. Refer to chapter 9 (Replacing the Shear Pins) for the position of the spare pins.

Tiger wire rope pullers are available in two models with the following capacities:

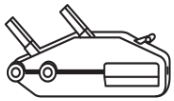

SPECIFICATIONS & DIMENSIONS (ALUMINIUM CASING)

Model Number (ALUMINIUM CASING)	WLL (kg)	Pulling Capacity (kg)	Rope Diameter (mm)	Breaking strain (kN)	Effort (kg)	Advance /Pull (mm)	Net Weight (kg)	Overall Length (mm)	Overall Height (mm)	Overall Width (mm)
TRPA-08	800	1200	8.3	43	35	52	6	426	235	64
TRPA-16	1600	2400	11	120	41	55	11	545	280	97
TRPA-32	3200	4800	16	162	45	28	22	660	325	116
TRPA-54	5400	8000	20	264	76	30	59	930	480	152

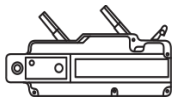

SPECIFICATIONS & DIMENSIONS (STEEL CASING)

Model Number (STEEL CASING)	WLL (kg)	Pulling Capacity (kg)	Rope Diameter (mm)	Breaking strain (kN)	Effort (kg)	Advance /Pull (mm)	Net Weight (kg)	Overall Length (mm)	Overall Height (mm)	Overall Width (mm)
TRPS-08	800	1200	8.3	43	35	52	8	440	265	63
TRPS-16	1600	2400	11	120	41	55	14.5	550	300	77
TRPS-32	3200	4800	16	162	45	28	28	690	350	91



The wire rope puller comes with a telescopic operating handle* and 20 metres of wire rope fitted with an eye-type hook as standard. Any length of rope can be supplied to your requirements. Alternatively the wire rope puller is available as a machine only, without wire rope. (*the operating handle with the 800kg TRPA/TRPS is not telescopic)

This manual together with a test certificate or declaration of conformity will be supplied with each unit sold.

NOTE: The machines should be used with Tiger approved wire rope. You are strongly advised to carry out a risk assessment before selecting a manual puller for any proposed application.

2. Rigging Application

Various methods of rigging are shown. For the correct and incorrect method refer to figures 1 and 2. Other methods of rigging will increase the capacity of the machine – refer to figures 3 and 4.

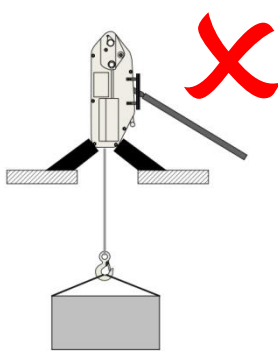

Figure 1

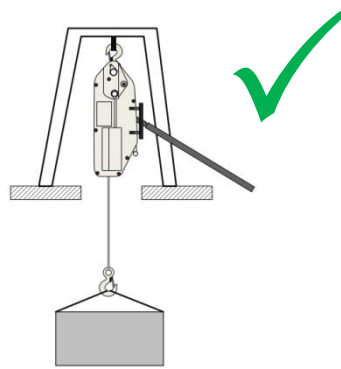

Figure 2

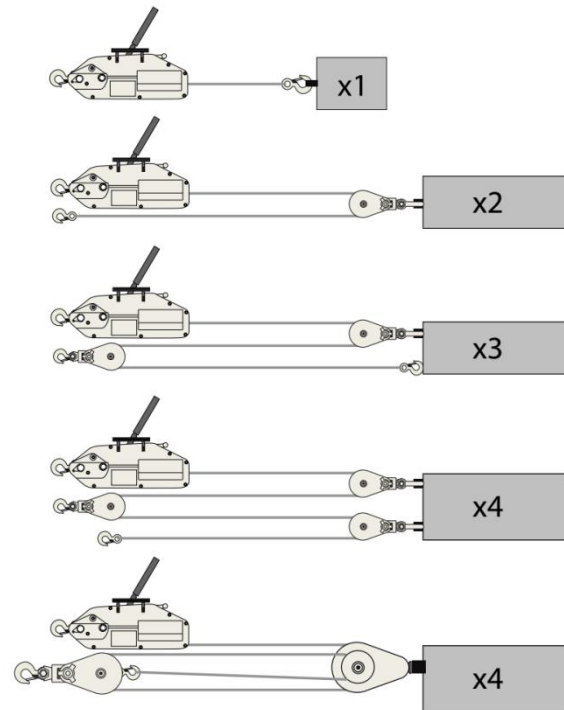

Figure 3

In examples 3 and 4 the maximum working load limit (WLL) of the pulley and anchor point shall be equal to or greater than two times the WLL.



NOTE: When the wire rope puller is anchored directly to a fixed point, ensure that there are no obstructions around the machine which could prevent the wire rope, puller and anchor from operating in a straight line.

It is recommended to use a sling of similar capacity between the anchor point and the unit.

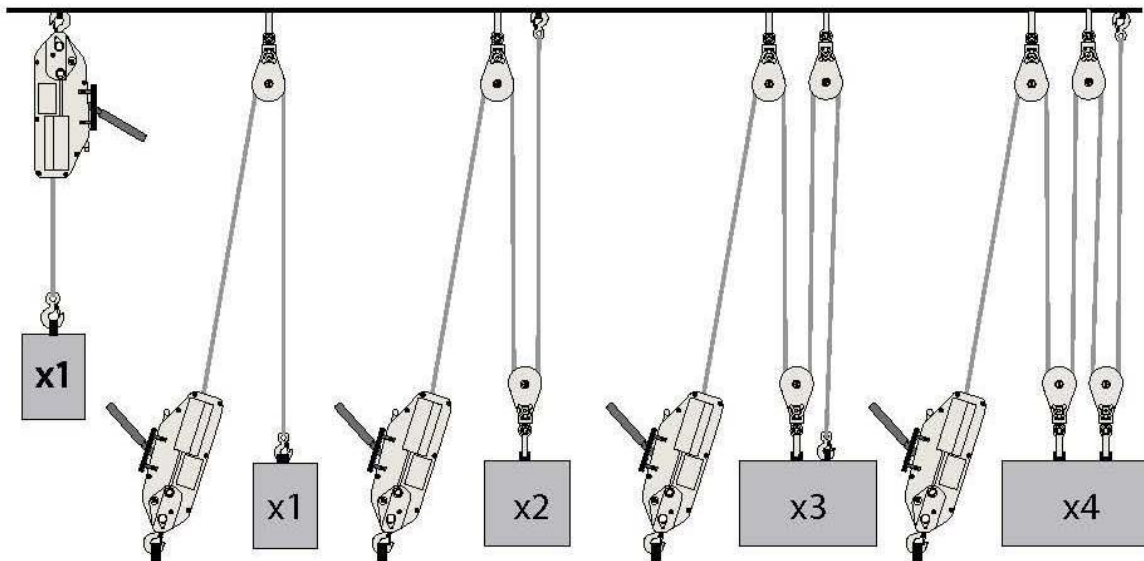

Figure 4

WARNING: Any rigging configuration which requires the calculation of forces applied should be checked by a competent engineer, with special attention to the strength of the fixed point used.

For tree felling work such as guiding the trunk, the operator should stand outside the danger area by passing the wire rope around one or more return pulleys.

The capacity of the wire puller can be increased considerably, for the same effort by the user, by utilising multiple sheave blocks (see figures 3 and 4).

The increase in capacity shown is reduced depending on the efficiency of the sheave blocks.

The diameter of the sheave blocks used should be equal to at least 18 times the diameter of the wire rope.

For a rigging setup other than those expressed in this manual, please consult a qualified structural engineer before operating the unit.

3. Installation of the Wire Rope

It is recommended that you use work gloves to protect your hands when handling the wire rope. If the wire rope is to be anchored to an elevated anchor point, the wire rope should be anchored first before fitting wire to the machine.

1. Uncoil the wire rope in a straight line to ensure there are no loops or kinks in the rope.
2. To release the jaws, push the lever to B position towards the anchor pin (see figures 5 and 6 and section 4).
3. Insert the wire rope tail end through the rope guide at the end opposite to the anchor point.
4. Push the wire rope through the machine, if necessary aiding it by operating the forward operating lever.
5. When the wire rope appears through the anchor point, pull up the slack wire rope through the wire rope pulling machine to the desired length.
6. To engage the jaws by operating the rope, release mechanism to A position towards the hook end (see figures 5 and 6).
7. Anchor the wire puller and/or the wire rope to the desired fixed anchor point; take care to ensure that the anchor point is fitted correctly.
8. Extend the telescopic operating handle until the spring pin locks into position. You may have to twist the two sections of the handle to locate the spring pin mechanism into the hole.
9. Place the operating handle on the chosen lever (forward or reverse) and twist the handle about half a turn to ensure it is locked into position.
10. After this procedure the wire puller is ready for operation, provided that the load is correctly anchored to the puller or the wire rope.

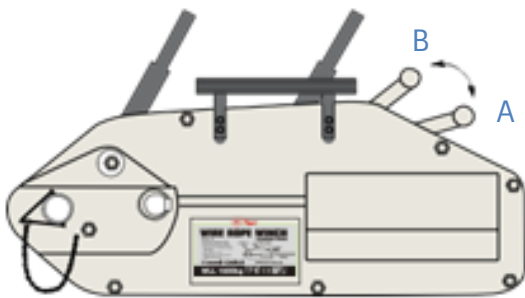

Figure 5 – TRPA (Aluminium)



Figure 6 – TRPS (Steel)

4. Releasing and Closing the Jaws

Each wire rope pulling machine is fitted with a lever (see figures 5 and 6) for releasing the jaw which should only be operated when the machine is not under load. There are only two positions for the rope release lever, release or engaged.



NOTE: When the puller is not in use the rope release lever should be in the engaged position (A). The puller must therefore be released before attempting to free the wire rope.

Releasing for the TRPS model

Place the anchor point against a support.

1. Completely press the rope release safety catch and push the rope release lever towards the anchor point.
2. Release the safety catch and continue to push the rope release lever until it locks into position. The internal mechanism is in the release position.

Engaging;

1. Push the rope release lever towards the anchor point until it clicks into position.
2. Press and maintain pressure on the rope release safety catch, allowing the release lever to slowly travel back to its original position. Release the safety catch. The release lever locks in position under the effects of its spring.

Releasing for the TRPA model

Place the anchor point against a support.

1. Push the rope release lever downwards and forwards towards the anchor pin until it locks into position when raised slightly at its limit.

Engaging;

1. Press the rope release lever vertically downwards, allowing the lever to travel back to its original position under the effects of its spring.

5. Anchoring

Failure to anchor the wire rope pulling machine correctly runs the risk of serious injury. The user must always ensure before operation that the anchor points for the puller and wire rope are of secure and of adequate for the imposed loads.

It is recommended that the puller should be anchored to a fixed point or to the load using an appropriate capacity sling. It is forbidden to use the unit's wire rope as a sling by passing it around the anchor and hooking it around back onto itself (see figure 7).

In all cases when anchoring the wire puller, the safety catch of the anchor hook should be correctly closed in its position at the tip of the hook, this also applies to the hook fitted to the wire rope. The wire puller is anchored by means of a removable pin, fitted across the two ends of the side cases and locked in place by an R clip.



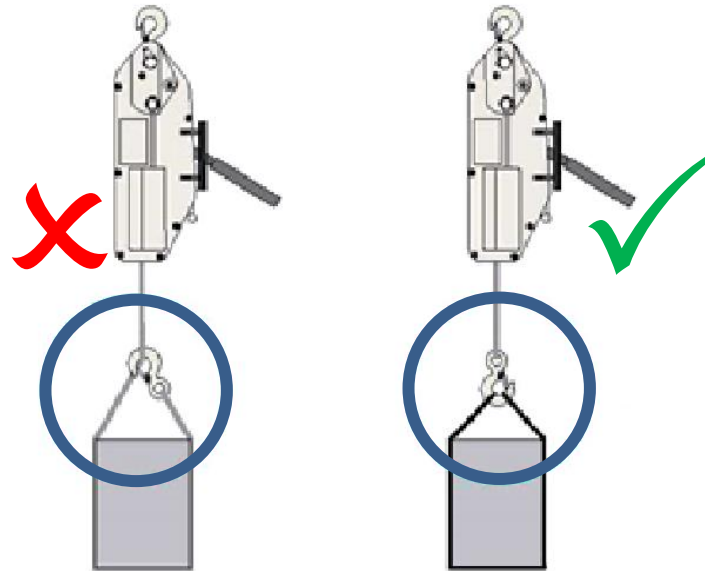
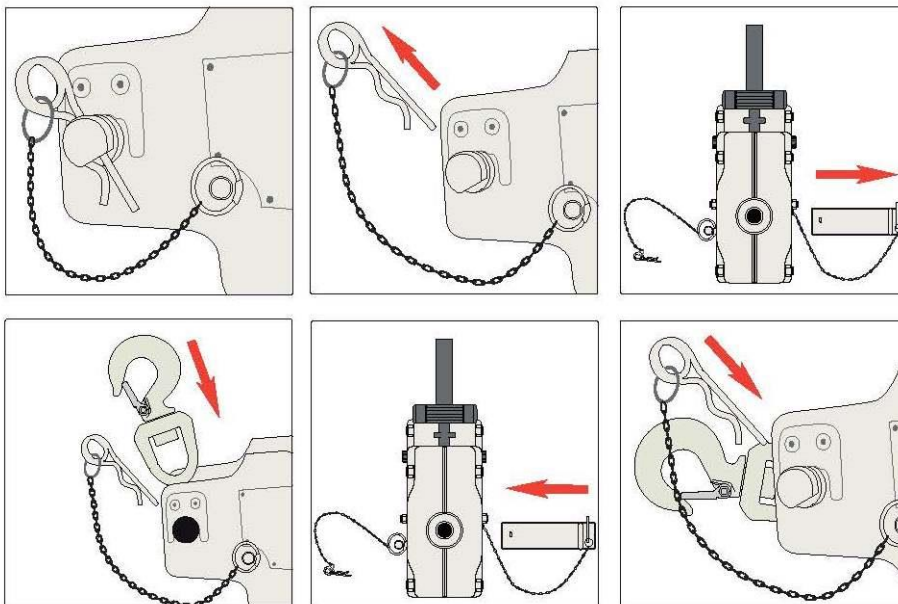

Figure 7



WARNING:

It is essential for the safe operation of the wire puller to ensure that before loading the machine the anchor points, hooks or pins are correctly secured with the safety catch correctly located on any hooks.

1. Open the R clip of the anchor pin
2. Remove the spring clip from the anchor pin.
3. Slide the anchor pin out of the side cases
4. Fit the anchoring arrangement between the side cases.
5. Refit the anchor pin through the side cases and anchoring arrangement.
6. Refit the spring clip to the anchor pin. Close the spring clip ensuring that it is fitted correctly over the end of the anchor pin and cannot be dislodged.



6. Operation

Tiger wire rope pullers are very easy to use. Place the telescopic operating handle on either the forward or reverse operating lever then lock it into position by twisting the handle till it has locked in, and move the handle forwards and backwards. The operating arc of the handle is variable for ease of operation.

When operation stops both jaws automatically grip on the wire rope and this holds the load with an equal load on both jaws. The to and fro operation of the forward or reverse lever gives continuous movement of the load.

Ensure the machine is free to align correctly with the rope and the rope is not twisted, trapped and is free of any obstructions.

WARNING: Never operate the forward and reverse levers at the same time. Never force the operating levers. Never use operating handles other than the telescopic operating handle designed for the machine in use. Never lift on the point of the hook or overcrowd the hook with fittings.

7. Releasing the Wire Rope and Storage

You must take the load off the puller before attempting to release the jaws. To do this, operate the reverse operating lever until all tension is off the wire rope.

Remove the telescopic operating handle and return it to the closed position. Release the wire puller and follow the instructions for installing the wire rope in reverse order. Re-engage the jaws of the puller before putting it into storage.

Inspect the machine, rope and accessories before placing into storage. Never return damaged machines, rope or accessories to storage. Store the items in a dry area away from the effects of the weather, so they are protected from corrosion. The wire rope should be completely removed from the wire puller and rewound onto its spool or suitable drum or frame, taking care to avoid any twists. Store machines and ropes on a suitable rack, not on the floor where they may be damaged.

8. Safety Features

All Tiger wire rope pullers incorporate a shear pin system. In case of overloading, one pin is fitted to the forward operating lever and will shear to prevent further forward or lifting operations. Reverse operation is still possible to enable the load to be lowered or wire rope to be slackened.

They are fitted with a two handed rope release system which requires deliberate operation by the user to release the machine. (Refer to section 4 – Releasing and closing the jaws.)





9. Replacing the Shear Pins

Figures 8 and 9 show the position of the shear pins and replacement shear pins for both models. Spare shear pins are located in the carry handle of the wire puller for model TRPA (1600kg-5400kg capacities), in the operating handle of the TRPA-08 (800kg capacity), and in the rope release lever for model TRPS, behind the plastic caps.

Remove the sheared pin with a suitable punch. Then align the holes of the upper and lower sections of the forward operating lever. Position the spare shear pin and drive it in with a hammer. Before putting the wire puller back into operation, ensure that the cause of the overload is removed. If necessary, use multiple sheave blocks. Don't forget to re-order replacement shear pins and put them back in the correct place.

Warning: It is forbidden to replace sheared pins by anything other than genuine Tiger shear pins of the same model.

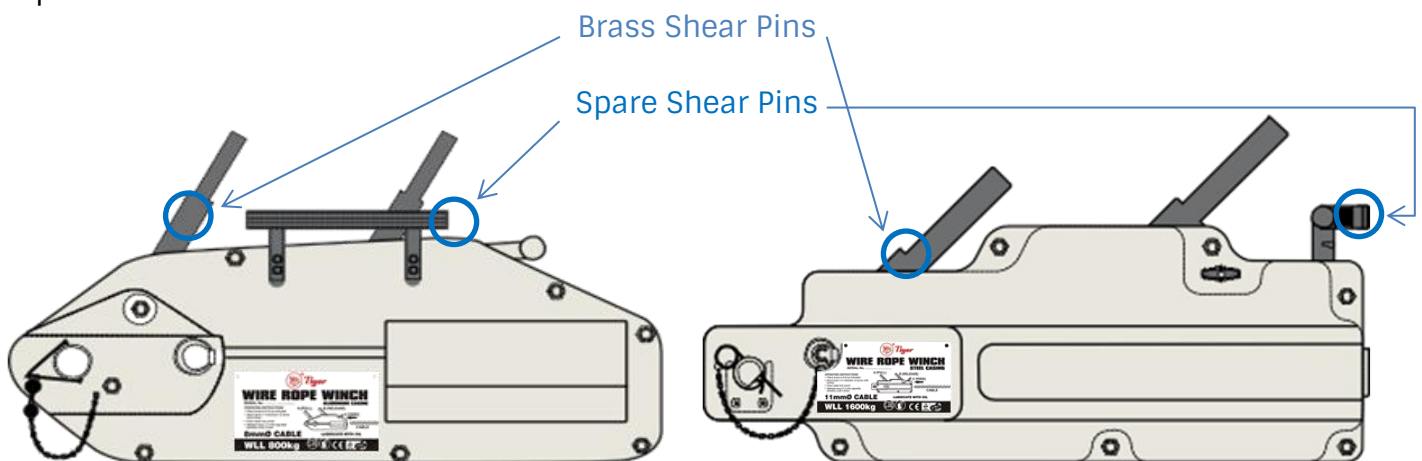

Figure 8 – TRPA (Aluminium)

Figure 9 – TRPS (Steel)

10. Wire Rope

To guarantee the safe operation of Tiger wire rope pullers it is essential to use them with wire rope which has been specially designed to meet the requirements of the puller. Tiger wire rope supplied with the wire puller is 6x19 with steel core (8.3 and 11mm) and 6x19 IWRC (16mm and 20mm). It will have a thimble eye machined splice with an eye hook at one end. The other end is fused and tapered.

The wire rope needs to be maintained in good condition and should be examined daily to detect any signs of wear (kinked, damaged or broken wires). In the case of apparent wear, have the wire rope inspected by a qualified person. Any wire rope with a reduction from the nominal diameter by more than 10% should be replaced. Figure 10 shows the correct method for measuring the diameter of a wire rope.

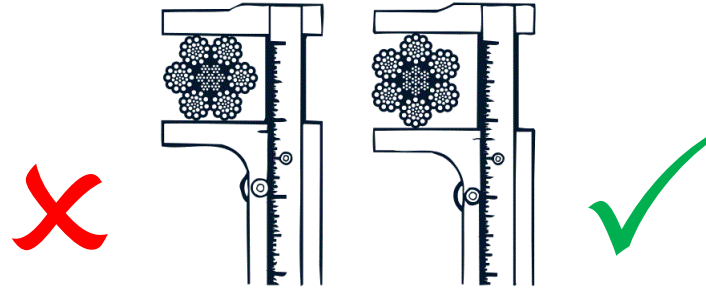

Figure 10

IMPORTANT: It is recommended, especially for lifting applications, that you ensure that the length of wire rope is longer than actually required. Allow approximately an extra metre for the job. When lifting or lowering loads over long lengths of wire rope, take operating steps to stop the load from rotating, to prevent the wire rope lay from unwinding.

Never allow a tensioned wire rope to rub over sharp edges. The wire rope must only be used with sheaves of an appropriate diameter.

Never use wire rope that has been subject to damage, such as fire, corrosive chemicals or atmosphere, or exposed to electric current.

11. Maintenance Instructions

A qualified repairer should inspect, clean and lubricate the wire rope pulling machine at regular intervals, at least once a year. Never use grease containing graphite additives or molybdenum disulphide. To clean the wire puller, allow the machine to soak in a bath of some proprietary cleansing fluid but not acetone and derivatives or ethylene trichloride and derivatives. Then shake the puller vigorously to loosen foreign matter and turn it upside down to allow the dirt to come out through the openings of the operating levers. Allow the mechanism to drain and become dry. After this treatment, ensure that the wire puller is well lubricated with suitable oil onto the internal mechanism through the openings of the operating levers. To carry out this procedure, it is best for the wire puller not to be under load and in the release position. Alternatively operate the forward and reverse operating levers to allow the lubricant to penetrate all parts of the mechanism.

Note: Excess lubrication cannot cause the puller or wire rope to slip.

Any wire rope pulling machine where the side cases show signs of dents or damage, or of which the hook is damaged should be returned to an approved distributor for repairs.



12. Warnings Against Hazardous Operations

We would like to draw the attention of the users to the following warnings:

- Tiger wire pulling machines, as described in this manual, must not be used for lifting people.
- Never attempt to motorize the models of wire rope pulling machine as described in this manual.
- Do not exceed the working load limit (WLL), or for pulling applications, the Pulling Capacity.
- Wire pullers must not be used for applications other than those for which they are intended.
- Never attempt to operate the rope release mechanism whilst the puller is under load.
- Never obstruct the operating levers or rope release lever.
- Never operate the forward and reverse levers at the same time.
- Never use a handle other than the telescopic operating handle provided with the wire puller to operate the machine.
- It is forbidden to replace shear pins by anything other than genuine shear pins of the same model.
- Never anchor the wire puller other than by its appropriate anchor point.
- Never obstruct the wire puller which could prevent the machine, the wire rope and the anchor points from operating in a straight line.
- Never use the puller's wire rope as a sling.
- Never apply a load to the tail end part of the wire rope from the anchor point of the wire puller.
- Never subject the controls to hard knocks.
- Never attempt to reverse the wire rope completely through the puller whilst under load.
- Do not operate the puller when the ferrules get to within 10cm of the machine, otherwise the ferrule is likely to push through the rope guide inside the machine.
- Never lift on the point of the hook or overcrowd the hook with fittings.
- Never allow the load to swing out of control.
- Never leave a suspended load unattended.
- Never allow anyone to pass under or ride upon the load.





13. Troubleshooting

The forward operating lever moves freely and does not operate the mechanism	The wire puller has been overloaded and the shear pin has sheared. See section 9 for replacing the shear pin.
Pumping	A lack of lubricant in a wire puller sometimes brings a condition known as pumping which is not at all dangerous, though it is inconvenient. This situation occurs when the jaw which is gripping the rope becomes locked onto it preventing the other jaw from taking over the load. As the operating lever is moved in one direction the puller travels a few centimetres but when the operating lever travels in the other direction the puller moves back the same distance in sympathy with the jaw which is locked onto the wire rope. Once the puller has been thoroughly lubricated it will start working normally.
Jerky movement	This is also a sign of lack of lubrication. The puller should be thoroughly lubricated.
Blockage	If the wire rope becomes blocked in the puller, generally because a damaged section of the wire rope is stuck within the jaws, it is imperative to stop operating the puller. The load should be taken up by another puller on a separate wire rope, or by other means, whilst ensuring that all safety measures are taken. When the blocked puller is no longer under load the damaged rope may be released and removed. If this is not possible, return the wire puller and wire rope to an authorized Tiger Puller dealer for repairs and if necessary retesting.

14. Health and Safety at Work

All lifting equipment must be supplied, operated, maintained and tested to the provisions of the relevant occupational health and safety standards at the work place.

It is also the responsibility of every company to ensure that their employees have been fully and properly trained in the safe operation of their equipment.





15: Exploded diagrams

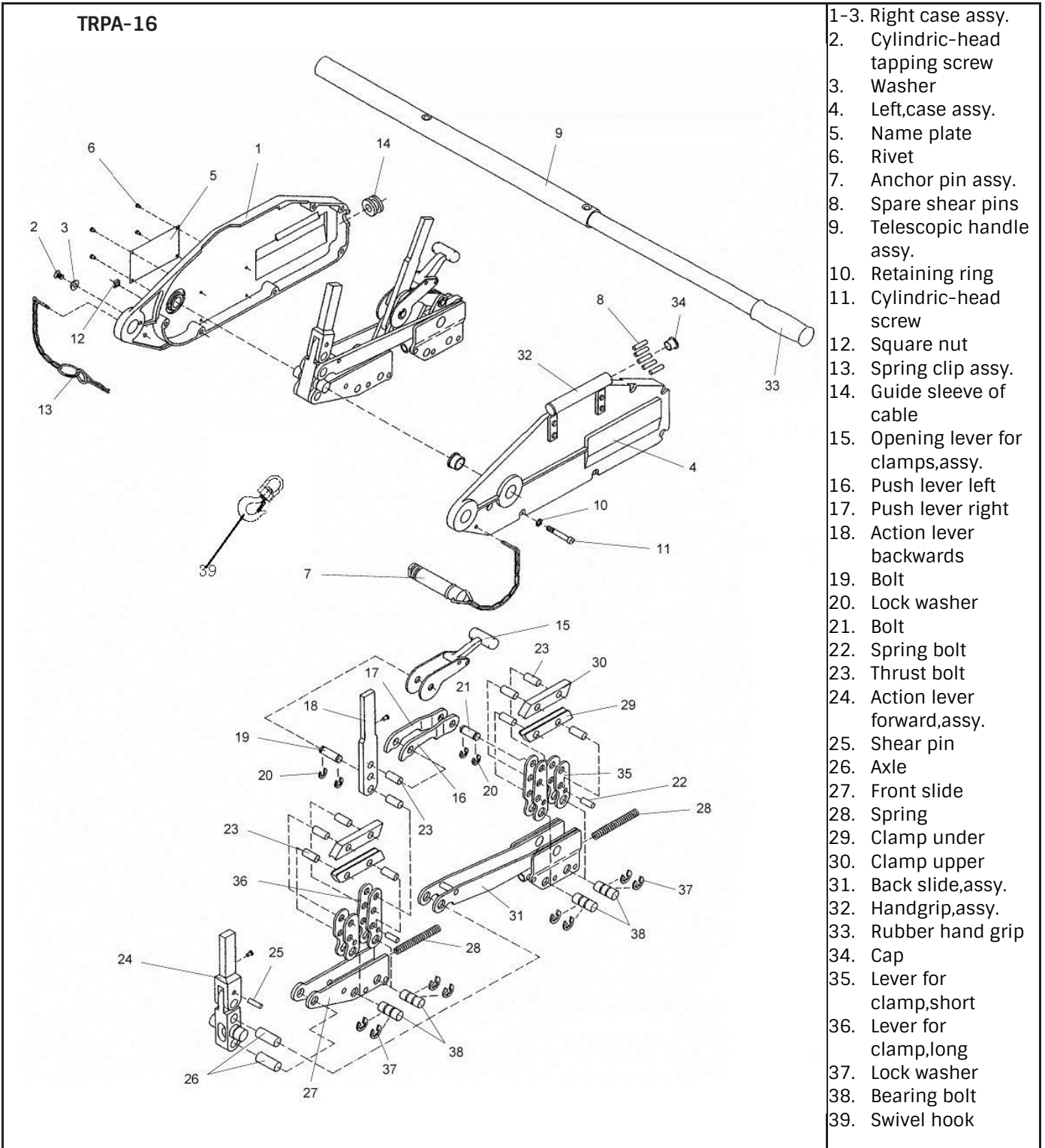

TRPS-16

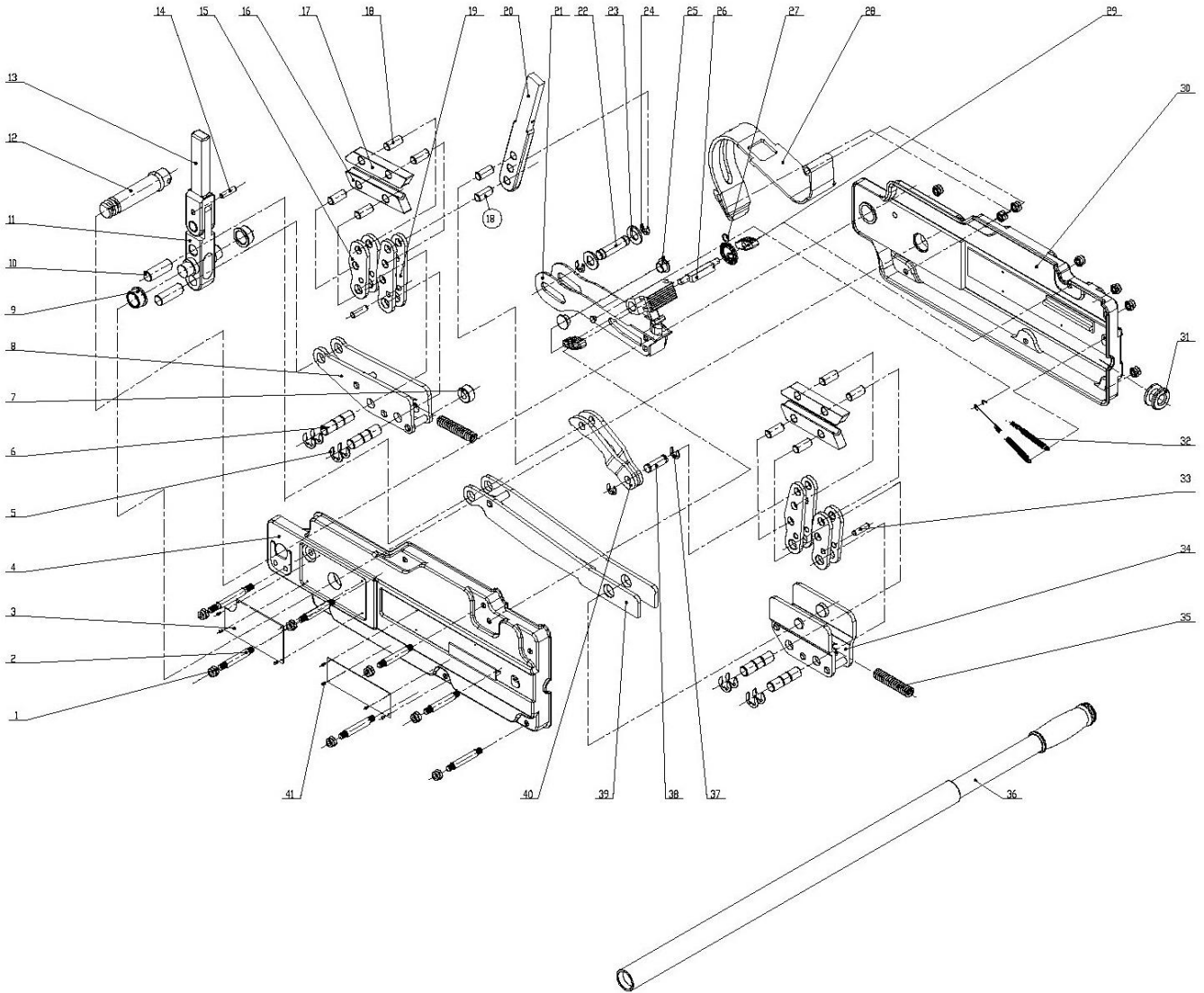

1. Square nut	13. Action lever fwd assy 2	24. Washer lock	36. Telescopic handle assy
2. Cylindric head screw	14. Shear pin	25. Cap	37. Lock washer
3. Name plate	15. Lever for clamp short	26. Switch shaft	38. Bolt
4. Left case	16. Top clamp	27. Torsional spring	39. Long connecting rod
5. Lock washer	17. Bottom clamp	28. Dust cover	40. Push lever
6. Bearing bolt	18. Thrust bolt	29. Switch knob	41. Rivet
7. Roller	19. Lever for clamp long	30. Right case	
8. Front slide	20. Action lever backwards	31. Wire rope guide sleeve	
9. Sleeve	21. Opening lever for clamps assy	32. Pull back spring	
10. Rocker shaft	22. Shaft	33. Spring bolt	
11. Action lever fwd assy 1	23. Washer	34. Back slide	
12. Anchor pin assy.		35. Spring	



Tiger Taiwan

Woo Sing Industrial Co., Ltd

No 20 Yunong Road

Shih-lin

Taipei

Taiwan

Phone: +886-2-2831 3035

Fax: +886-2-2834 0188

info@tigerlifting.com.tw

Tiger UK

Tiger Lifting UK Limited

Unit 1, Greensfield Industrial Estate,

Willowburn Avenue,

ALNWICK,

NE66 2DG

UK

Phone: +44 1665 605130

Fax: +44 1665 603185

info@tigerlifting.com

www.tigerlifting.com



© Copyright Tiger Lifting UK Limited. No part of this manual shall be reproduced, transmitted, transcribed, translated into any language human or electronic, stored in any electronic retrieval system, in any form without the written permission of Tiger Lifting UK Limited, Alnwick, UK

www.tigerlifting.com



Manual Tiger TRPS TRPA En 201510 v1.1